

CHECK VALVE

CDVN-XXX-PANS

MONODIRECTIONAL
POPPET TYPE

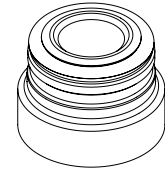
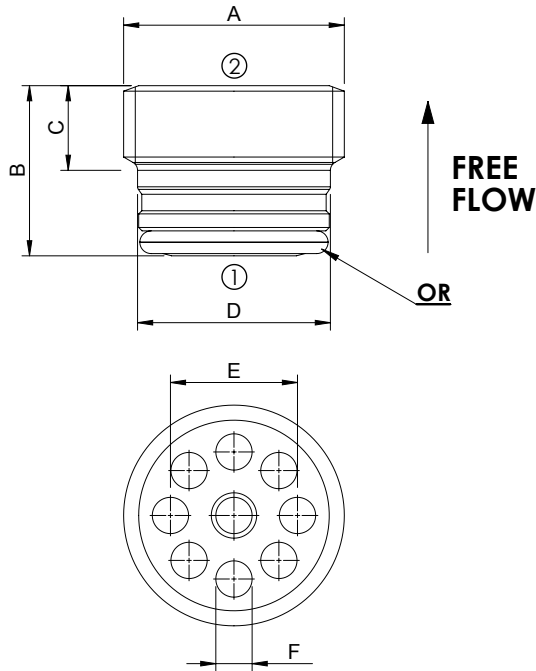

SPECIFICATIONS

Max. operating pressure: 350 bar

Quick code	A	B	C	D	E	F	OR
CD000173	G 1/8"	7.5	3.5	8.5	5.6	1.6	6.00 x 1 N70
CD000174	G 1/4"	8.5	4.4	11.4	8.4	2.2	9.00 x 1 N70
CD000175	G 3/8"	11.3	6.0	14.9	11.1	3.0	10.82 x 1.78 N70
CD000176	G 1/2"	12.7	6.5	18.5	13.5	3.8	14.00 x 1.78 N70
CD000178	G 3/4"	14.8	7.6	24.0	16.5	5.0	18.77 x 1.78 N70

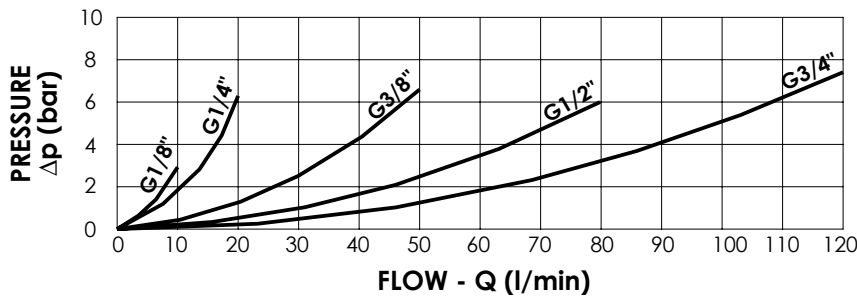

NOTES

Hardened seat and piston
Fatigue cycle life @ 350 bar, @ 1 Hz, and nominal flow: >1 million cycle

ORDERING CODES

Quick code	Description	Cracking pressure (bar)	Rated flow (l/min)	Cavity	Installation torque (Nm)	Installation tool
CD000173	CDVN-010-PANS-307-N001	0.3	10	VP000307 (G1/8")	5	UM000096
CD000174	CDVN-020-PANS-309-N001	0.3	20	VP000309 (G1/4")	6	UM000097
CD000175	CDVN-050-PANS-310-N001	0.3	50	VP000310 (G3/8")	6	UM000098
CD000176	CDVN-080-PANS-311-N001	0.3	80	VP000311 (G1/2")	10	UM000099
CD000178	CDVN-120-PANS-312-N001	0.3	120	VP000312 (G3/4")	15	UM000100